

REPLACEMENT PARTS

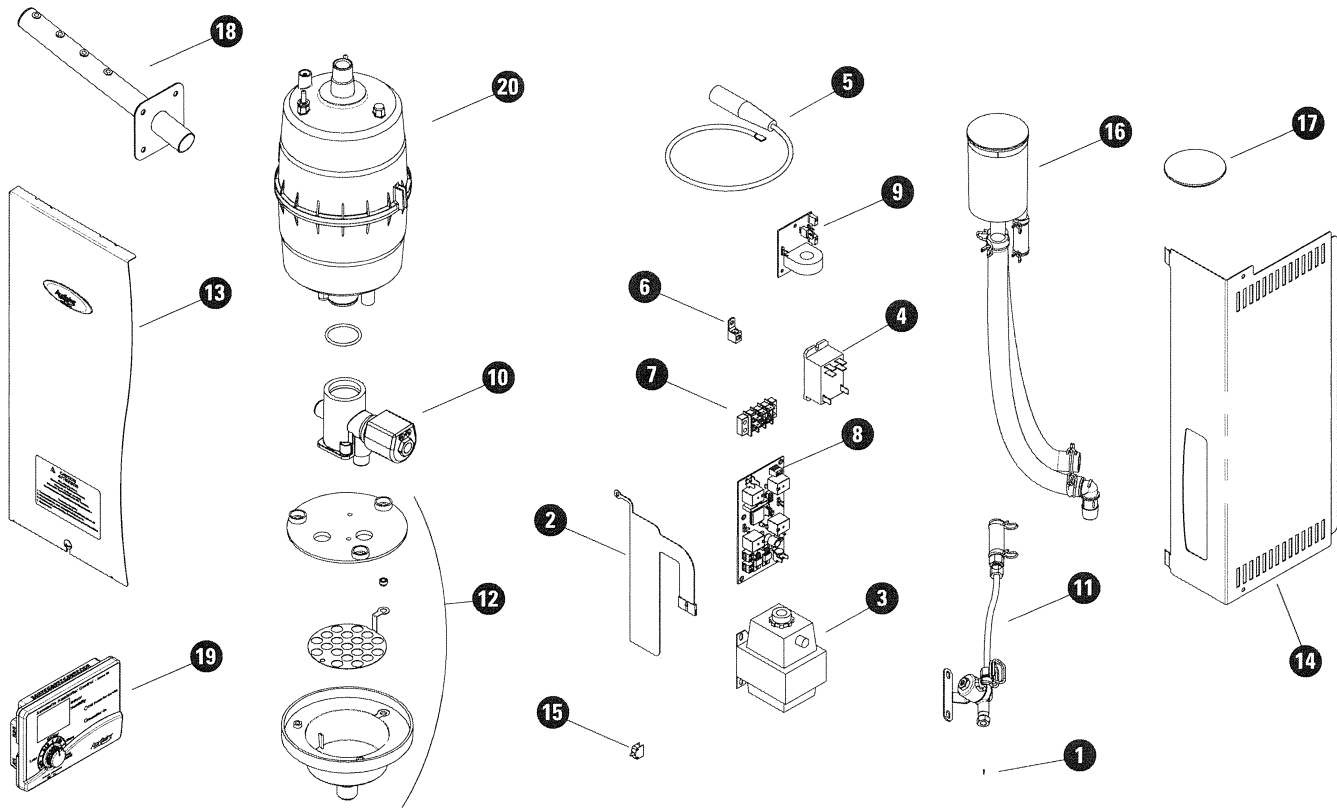

Item No.	Part No.	Description
1	4004	Fill Valve In-line Strainer
2	4975	Membrane Switch
3	4976	Transformer, Model 800
4	4977	Power Relay
5	4978	Electrode Wire (1)
6	4979	Ground Lug
7	4980	Input Power Terminal Block
8	4981	Internal Control Circuit Board
9	4982	Current Sensing Circuit Board
10	4983	Drain Valve
11	4984	Inlet Fill Valve & Water Feed System
12	4985	Drain Cup Assembly
13	4986	Front Panel & Screw
14	4987	Electrical Access Panel & Screws

Item No.	Part No.	Description
15	4988	Safety Interlock Switch
16	4989	Fill Cup and Hoses
17	4990	Fill Cup Cap
18	4991	Steam Dispersion Tube & Screws
19	62	Automatic Digital Control for Model 800
20	80	Steam Canister and O-Ring
	4001	Saddle Valve
	4993	Manual Humidistat & Blower Activation relay
	4592	Airflow Proving Switch
	4594	High Humidity Limit Switch
	4856	Condensate Pump (Rated for 160°F)
	4973	Steam Hose (6 ft.) & Clamps
	4974	Drain Hose (10 ft.) & Clamps